

## Inventor Drafting Problems Part 2

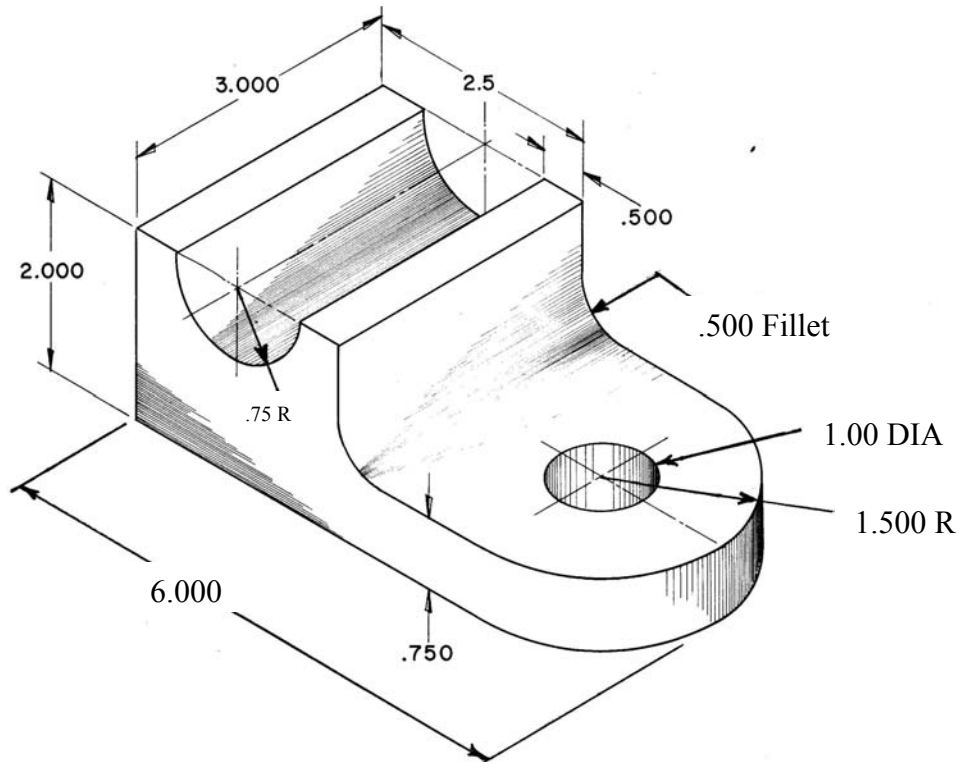

IN-22 Shaft Support

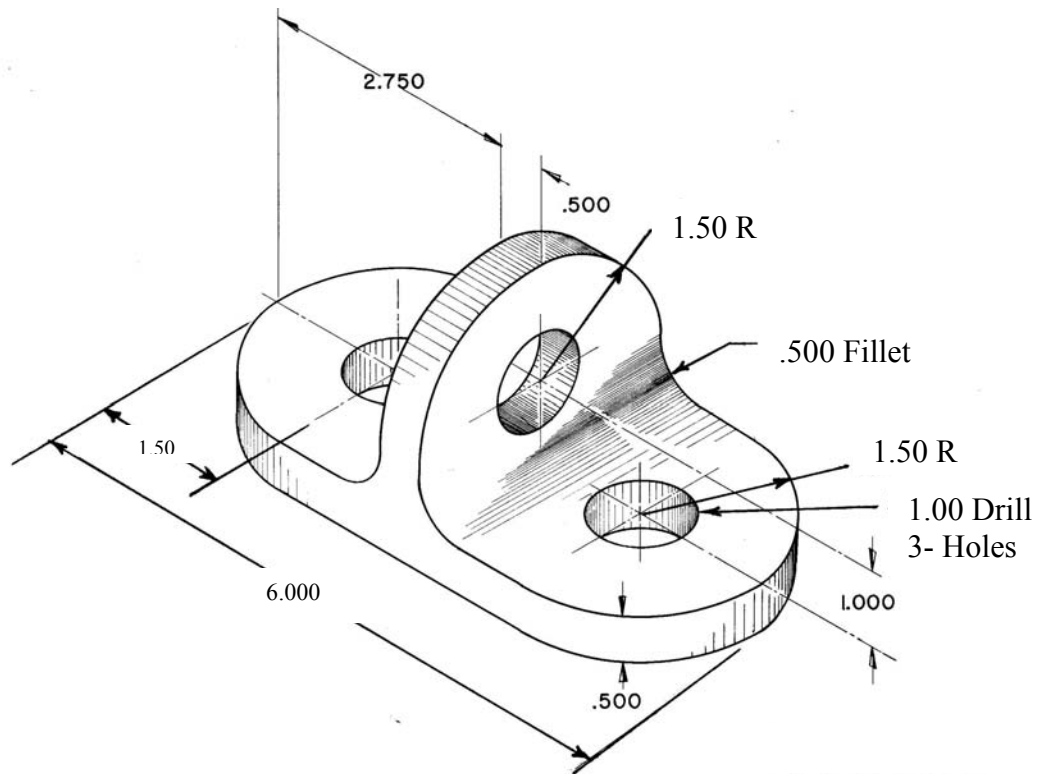

IN-23 Bracket

## Inventor Drafting Problems Part 2

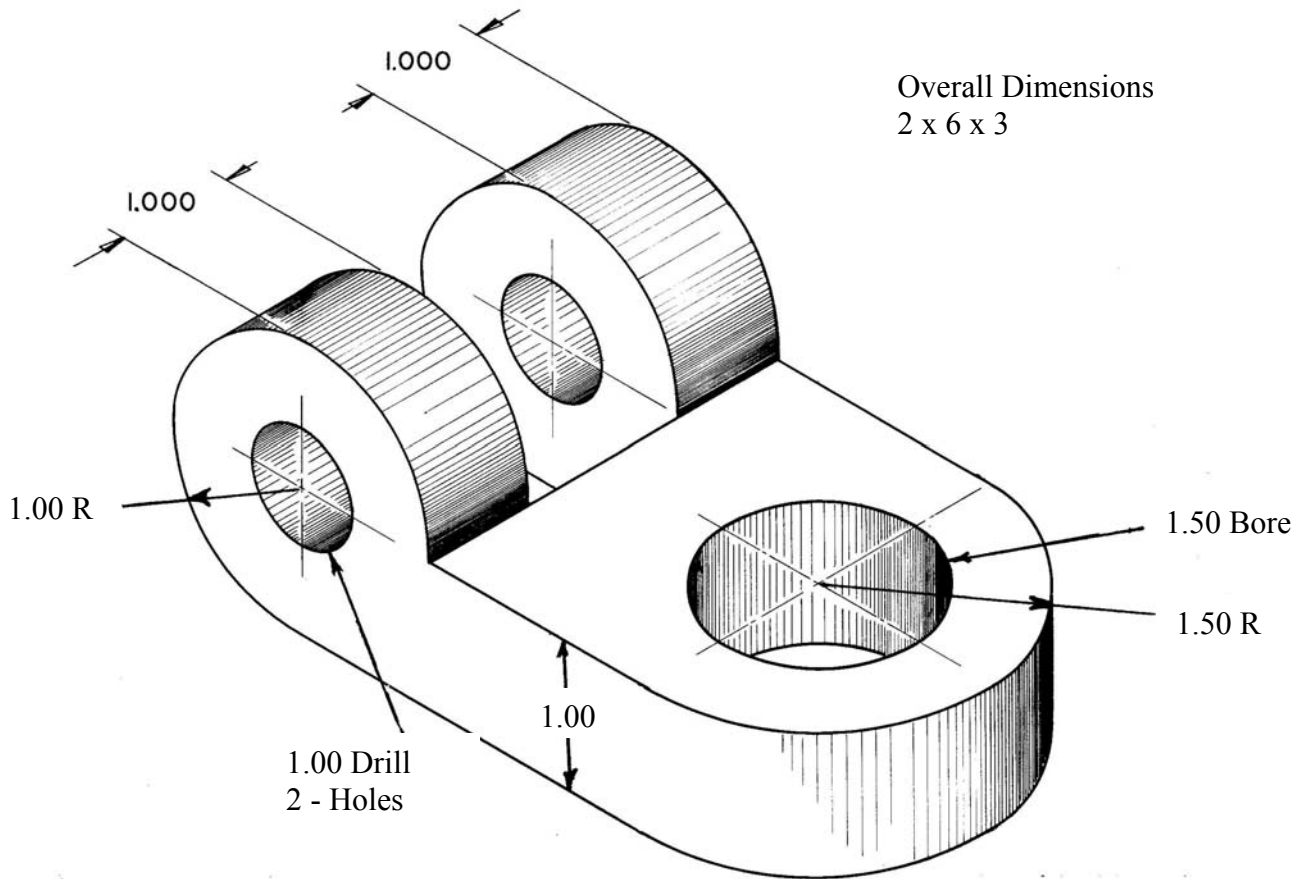

IN-24 - Reverse Link

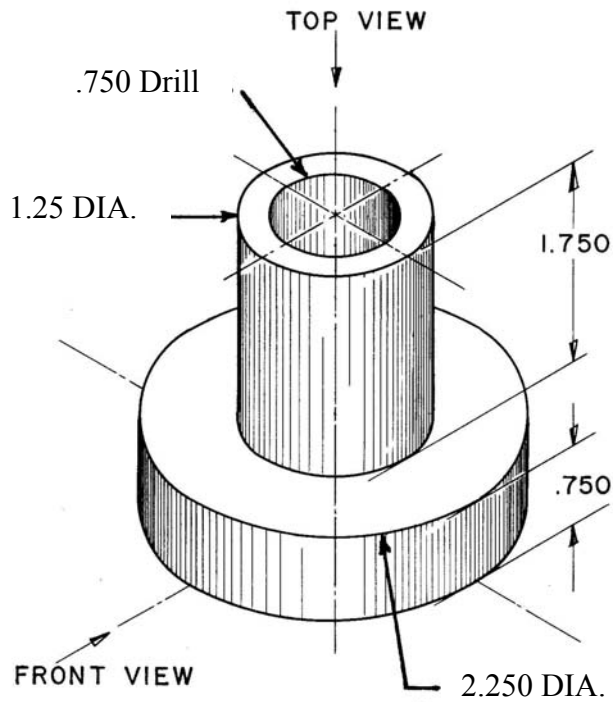

IN-25 - Flanged Bushing

## Inventor Drafting Problems Part 2

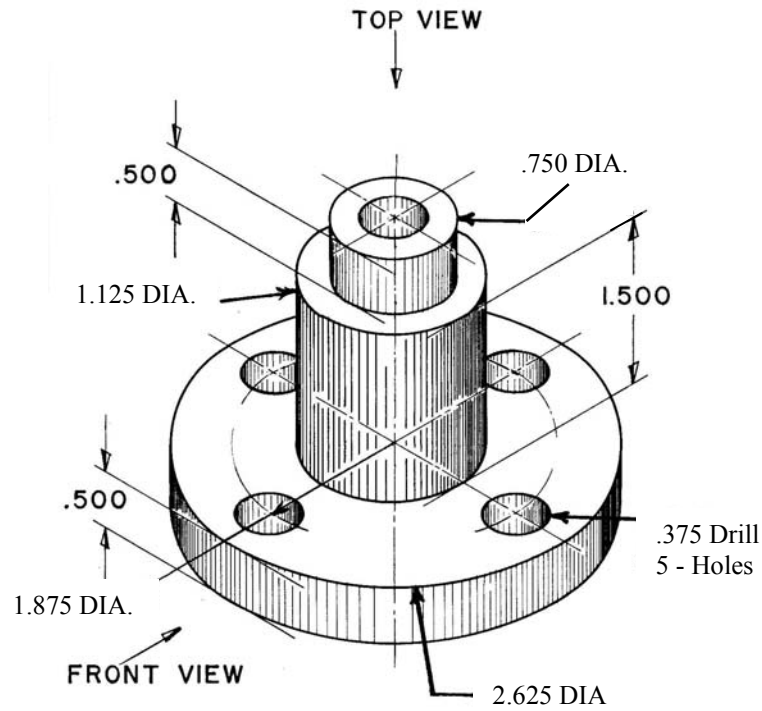

IN-26 - Shaft Support

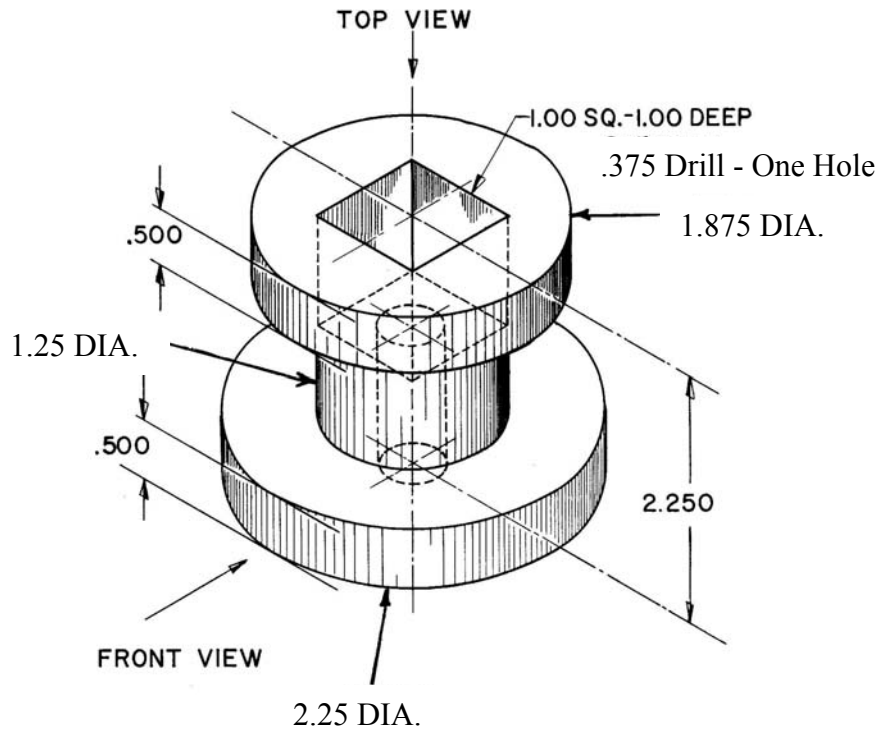

IN-27 Special Spacer

## Inventor Drafting Problems Part 2

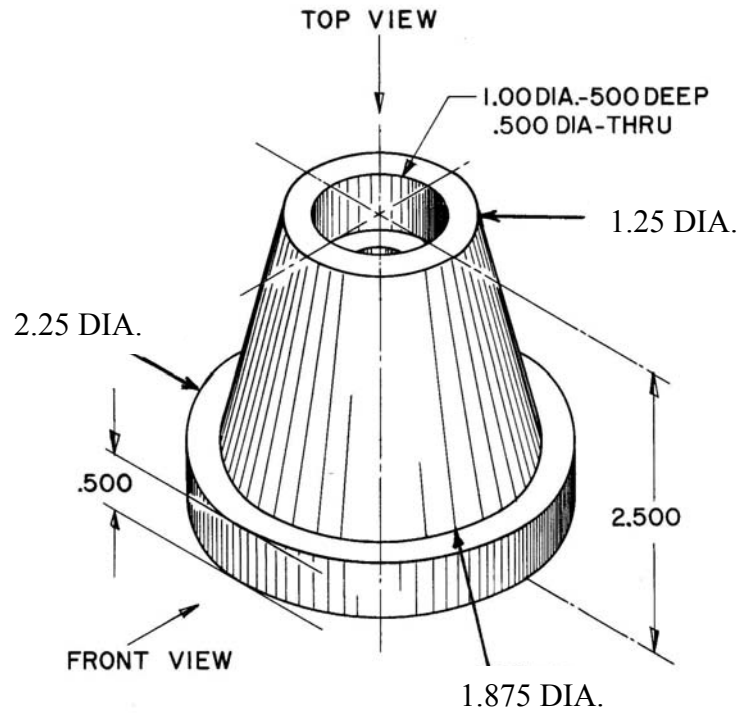

IN- 28 Tapered Support

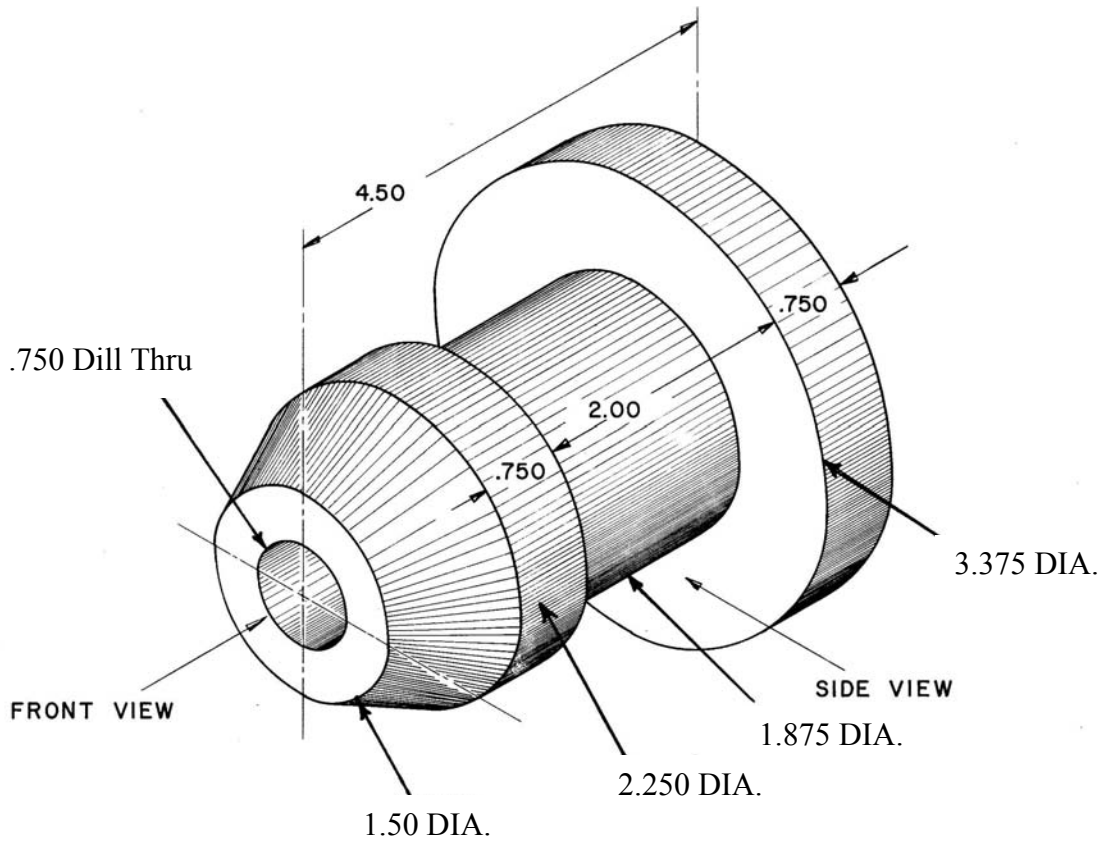

IN-29 Cone Support

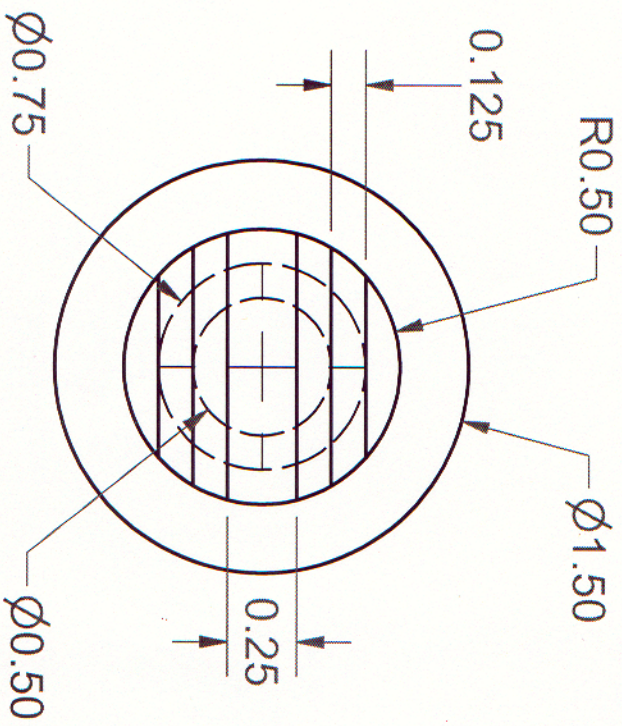
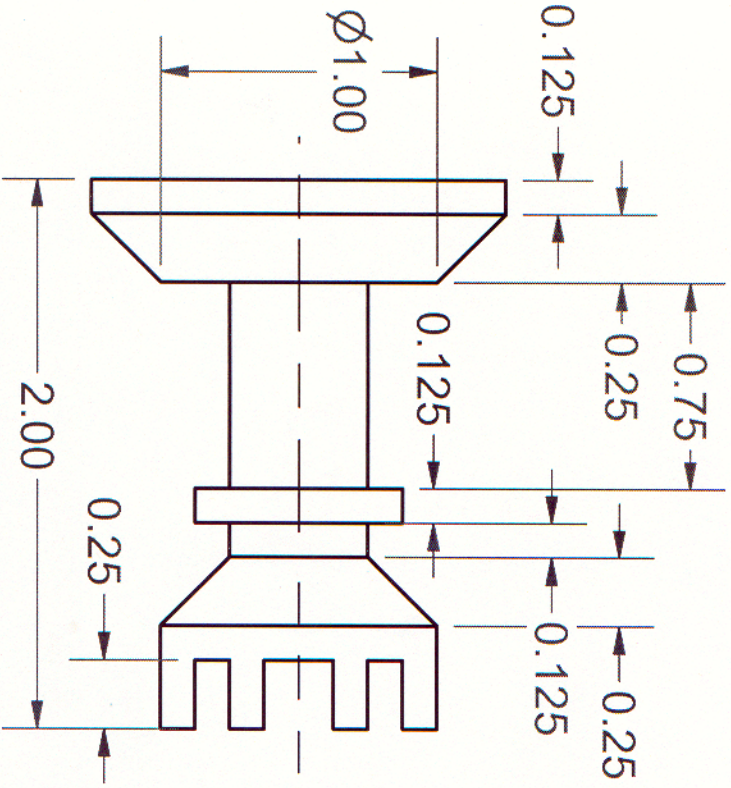
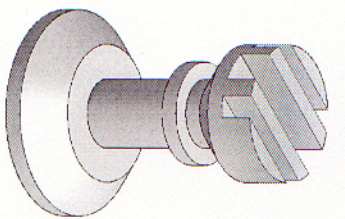

IN-30 - Chess Piece